



## Punching and Piercing Equipment

Bauromat design, manufacture and commission forming and piercing systems encompassing stretch bending equipment, multi-point pierce rigs and roll form stations.

In the building of equipment, Bauromat utilise its low cost manufacturing facility for mechanical manufacture of the major components.

All commercial elements are of worldwide brands to ensure local spares availability.

All Design is performed either in our UK facility or at one of our design partners within Europe to ensure all design is to customer's expectations and controlled locally.

All control systems are UK manufactured to ensure conformity to customer specifications and CE requirements.

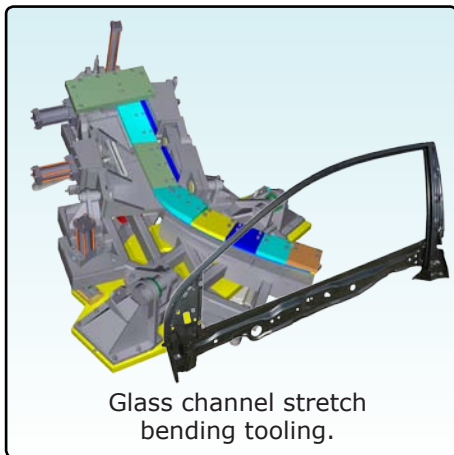

Glass channel stretch bending tooling.

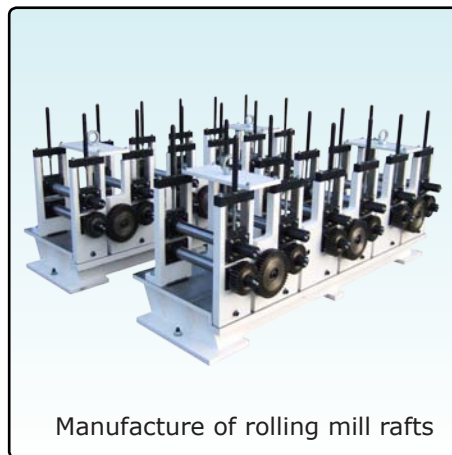

Manufacture of rolling mill rafts

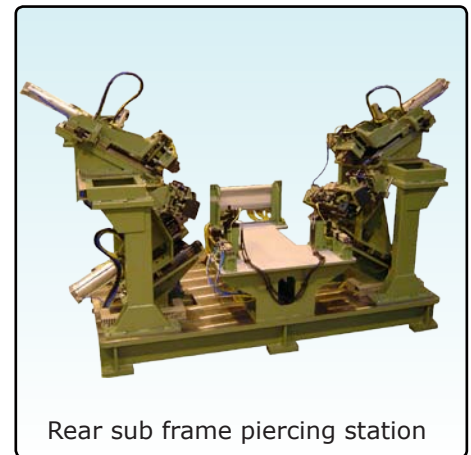

Rear sub frame piercing station

### Benefits of using Bauromat

- Very competitive pricing.
- Flexible working approach.
- CNC manufacture with 5 axis capacity.
- Wide range of design experience, allowing utilisation of many technologies.
- Quality control of materials.
- Turnkey project management.

Bauromat can also offer a complete package inclusive of fixtures for specific applications.

Along with training and service support from our modern purpose built factory.